

杭州凡诺电子有限公司  
FANNAL ELECTRONICS CO., LTD

**Specifications for Module**

Model NO: FN0100ON7S01

- Approved For Specifications Only  
 Approved For Specifications And Sample

FANNAL			CUSTOMER
PREPARED	CHECKED	APPROVED	APPROVED

Address: 6th Floor No.77 Xingwang West Road, Hangzhou, Zhejiang,

China Phone: +86 (0)571 85161516

<http://www.fannal.cn>

<http://www.fannal.com>

## Contents

Record of Revision.....	3
1 General Information.....	4
2 Mechanical Drawing.....	5
3 Pin Description.....	6
4 Absolute Maximum Ratings.....	7
5 Electrical Characteristics.....	8
6 Optical Characteristics.....	12
7 Environmental / Reliability Tests.....	15
8 Inspection criterion.....	16
9 Packing.....	21
10 Precautions For Use of LCD modules.....	22

FANNAL ELECTRONICS CO., LTD

**Record of Revision**

Rev	Issued Date	Description	Editor
1.0	2019/01/15	First Release.	

FANNAL ELECTRONICS CO., LTD

## 1 General Information

Item	Contents	Unit
Display Mode	AMOLED	/
Screen size	0.95(Diagonal)	inch
Resolution	180(RGB) × 120	/
Module area (W×H×T)	22.23 × 18.32 × 0.75	mm
Active area (W×H)	20.03 × 13.36	mm
Pixel pitch (W×H)	0.1113 × 0.1113	mm
Viewing direction	ALL	O' Clock
Interface Type	SPI	/
Luminance	350(typ)	cd/m2
Operating Temperature	-20 ~ +70	°C
OLED lifetime	100(min)	hour
Module Power consumption	TBD	W
Weight	0.83	g

Note 1: Viewing direction is follow the data which measured by optics equipment.

Note 2: Requirements on Environmental Protection: RoHS

Note 3: Weight tolerance: +/- 5

FANNAL ELECTRONICS CO., LTD

2 Mechanical Drawing

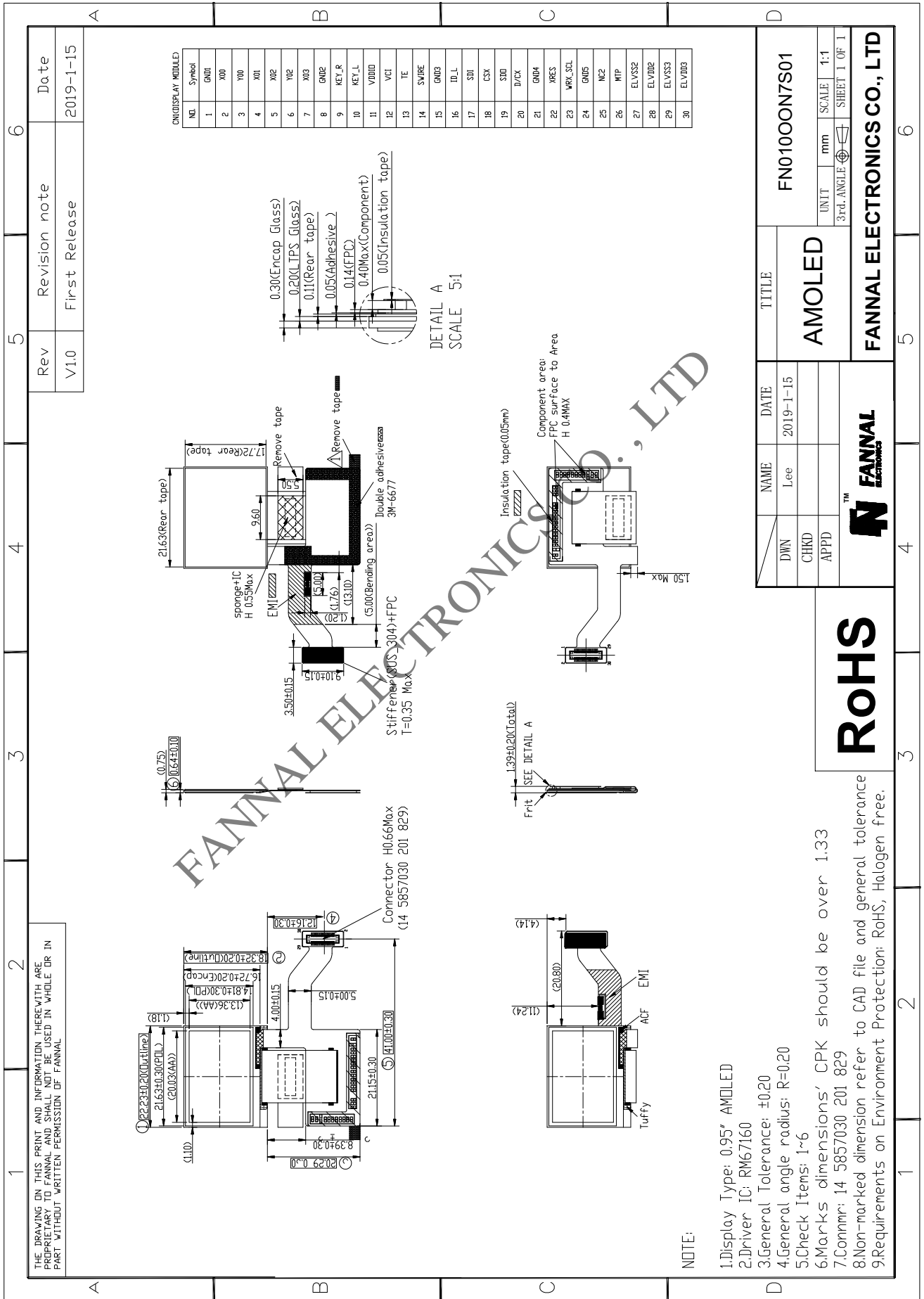

### 3 Pin Description

#### 3.1 PIN Definition

No.	Symbol	I/O	Description
1	GND1	P	The power ground
2	X00	I/O	Touch Panel trace
3	Y00	I/O	Touch Panel trace
4	X01	I/O	Touch Panel trace
5	X02	I/O	Touch Panel trace
6	Y02	I/O	Touch Panel trace
7	X03	I/O	Touch Panel trace
8	GND2	P	The power ground
9	KEY_R	-	Connect to KEY
10	KEY_L	-	Connect to KEY
11	VDDIO	P	Driver IC digital I/O supply
12	VCI	P	Driver IC analog supply
13	TE	O	Tear effect output
14	SWIRE	O	Swire protocol setting pin of Power IC
15	GND3	P	The power ground
16	ID_L	O	Panel ID pin
17	SDI	I	Serial input signal in SPI I/F. The data is input on the rising edge of the SCL signal.
18	CSX	I	Chip select input pin ( "Low" enable)
19	SDO	O	Serial output signal in SPI I/F. The data is output on the rising/falling edge of the SCL signal.
20	D/CX	I	Display data / command selection in 80-series MPU I/F and 4-wire SPI I/F. D/CX = " 0" : Command D/CX = " 1" : Display data or Parameter
21	GND4	P	The power ground
22	XRES	I	This signal will reset the device and must be applied to properly initialize the chip.Signal is active low
23	SCL	I	A synchronous clock signal in SPI I/F
24	GND5	P	The power ground
25	NC2	-	No Connection
26	MTP	P	Power supply for OTP. Leave the pin to open when not in use.
27	ELVSS2	P	AMOLED power Negative
28	ELVDD	P	AMOLED power Positive
29	ELVSS3	P	AMOLED power Negative
30	ELVDD	P	AMOLED power Positive

Note: I/O definition:I-----Input; O-----Output; P--- Power/Ground

#### 4 Absolute Maximum Ratings

Item	Symbol	Min	Max	Unit	Remark
Analog/boost power voltage	VDD	-0.3	5.5	V	
I/O voltage	VDDIO	-0.3	5.5	V	
Operating Temperature	T <sub>OP</sub>	-20	70	°C	
Storage Temperature	T <sub>ST</sub>	-40	80	°C	

Note:

1. If one of the above items is exceeded its maximum limitation momentarily, the quality of the product may be degraded. Absolute maximum limitation, therefore, specify the values exceeding which the product may be physically damaged. Be sure to use the product within the recommend range.

FANNAL ELECTRONICS CO., LTD

## 5 Electrical Characteristics

### 5.1 Driving Panel

Item	Symbol	MIN	TYP	MAX	Unit
AMOLED Power positive	ELVDD	4.55	4.6	4.65	V
AMOLED power Negative	ELVSS	-2.45	-2.4	-2.35	V
Digital Power supply	VDDIO	1.65	1.8	1.95	V
Analog Power supply	VCI	2.7	2.8	2.9	V

#### 5.1.1 Normal Mode

**Power Supply:** IOVCC=1.8V VCI=2.8V

**Frame Frequency:**  $F_{\text{frame}} = 60\text{HZ}$  @ 25degC, Brightness 350 nits, Command Mode,

Display Condition	Symbol	MIN	TYP	MAX	Unit
100% Pixel On 350nits	I <sub>ELVDD</sub>	-	8	8.8	mA
	I <sub>ELVSS</sub>	-	8	8.8	mA
	I <sub>VCI</sub>	-	6.0	7.2	mA
	I <sub>VDDIO</sub>	-	5.8	6.0	mA
50% Pixel On 175nits	I <sub>ELVDD</sub>	-	2.5	2.75	mA
	I <sub>ELVSS</sub>	-	2.5	2.75	mA
	I <sub>VCI</sub>	-	6.6	8.0	mA
	I <sub>VDDIO</sub>	-	5.8	6.0	mA

#### 5.1.2 Idle Mode

**Power Supply:** IOVCC=1.8V VCI=2.8V

**Frame Frequency:**  $F_{\text{frame}} = 15\text{HZ}$  @ 25degC, Brightness 30 nits, Command Mode,

Display Condition	Symbol	MIN	TYP	MAX	Unit
10% Pixel On 30nits	I <sub>ELVDD</sub>	-	-	-	mA
	I <sub>ELVSS</sub>	-	-	-	mA
	I <sub>VCI</sub>	-	4.5	5.4	mA
	I <sub>VDDIO</sub>	-	1.5	1.8	mA

#### 5.1.3 Normal Mode

Display Condition	Symbol	MIN	TYP	MAX	Unit
Deep Standby	I <sub>VCI</sub>	-	-	2	uA
	I <sub>VDDIO</sub>	-	-	1	uA



**5.2 Power supply circuit application (This is for reference only):**

**1) RT4723A**

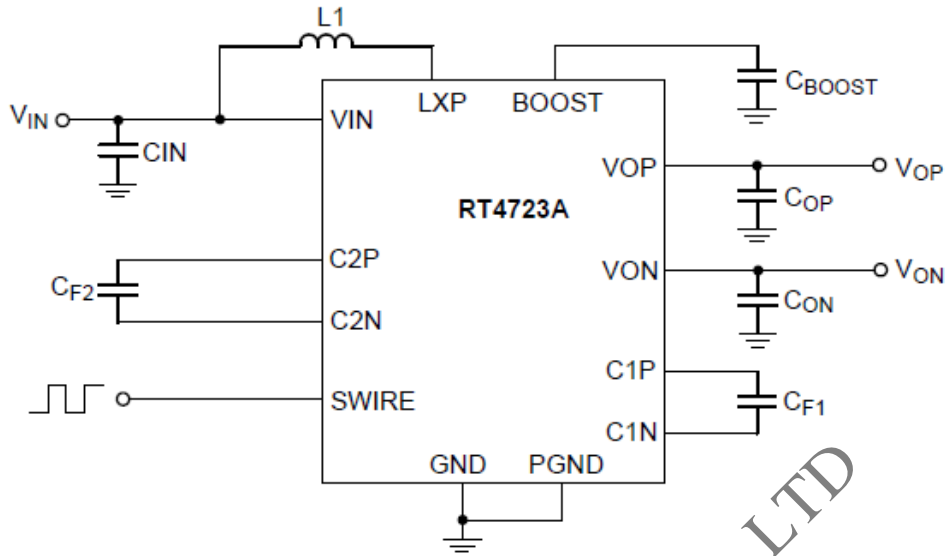

**2) SM3321**

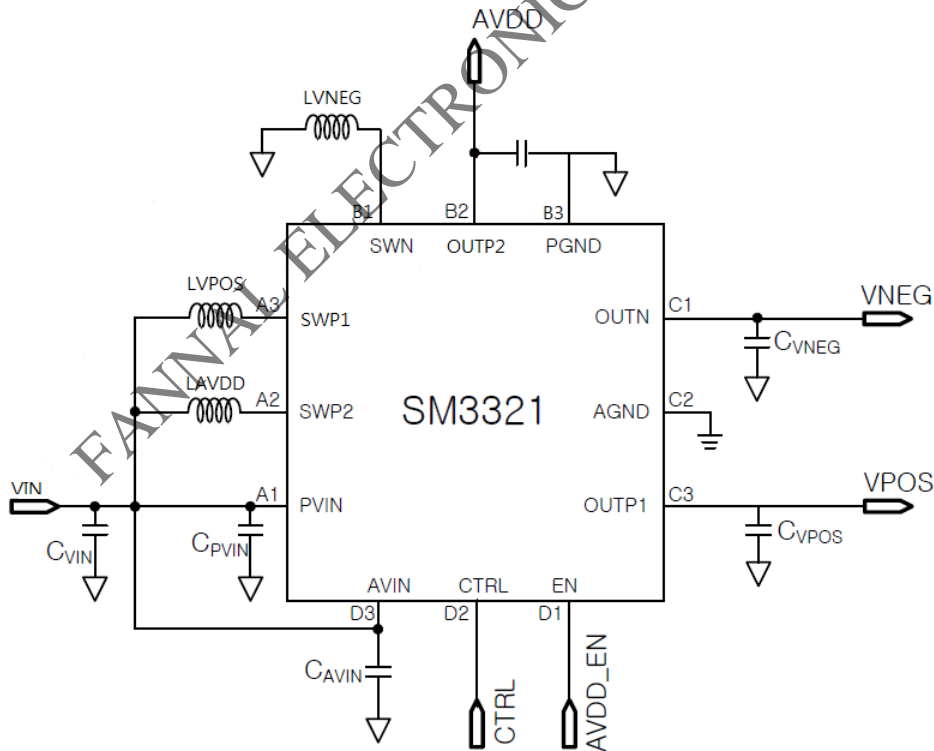

3) TPS65631W

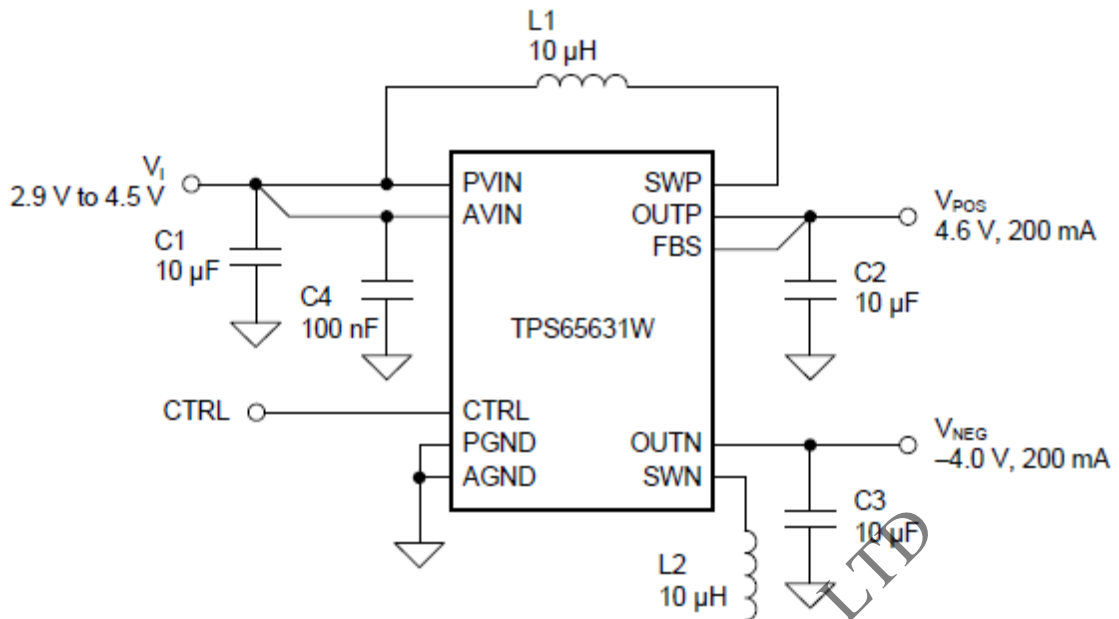

4) STAM1332

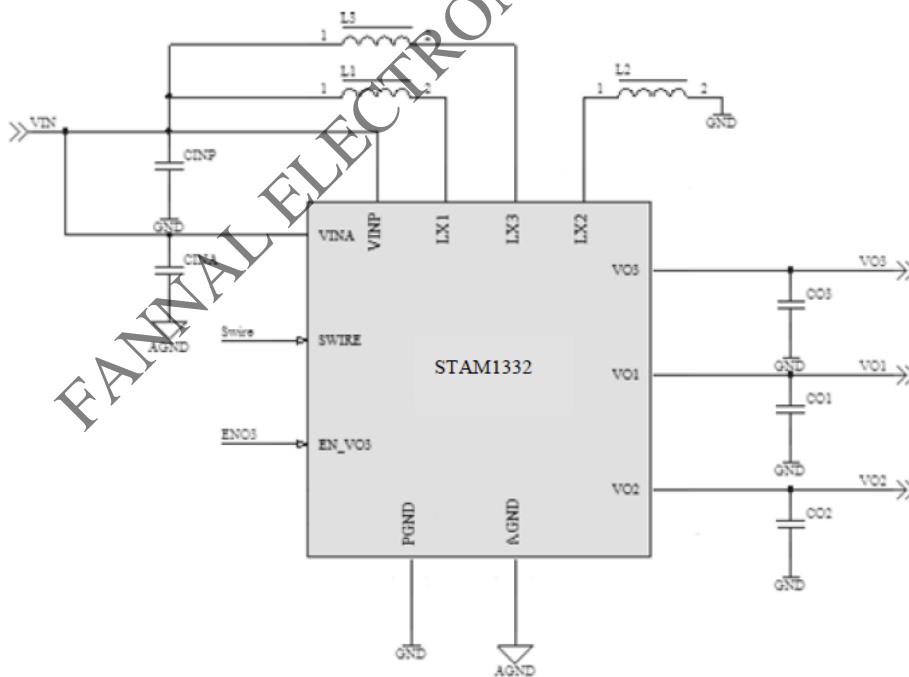

### 5.3 Recommended Operating Sequence

#### 5.3.1 Power on sequence

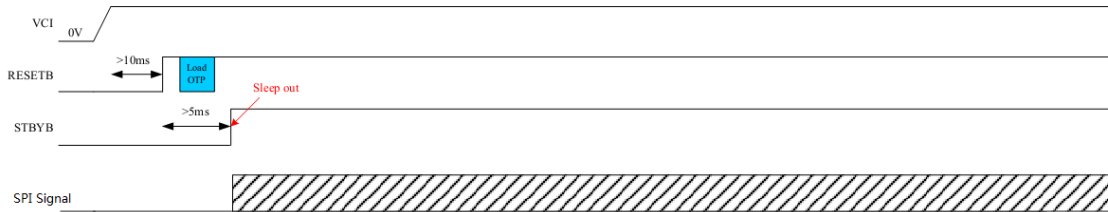

#### 5.3.2 Power off sequence

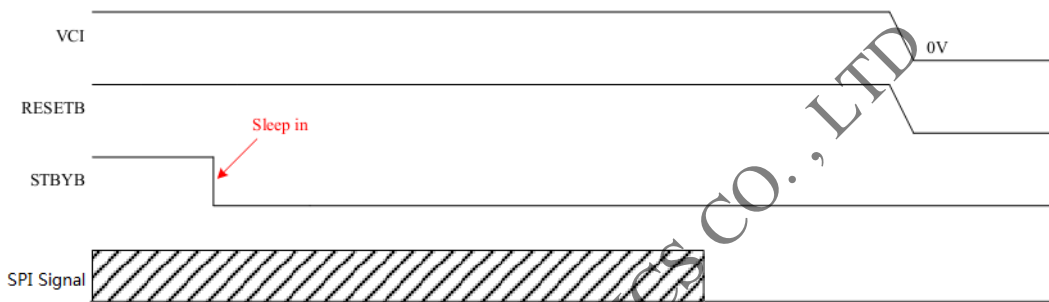

#### 5.3.3 Timing requirements for RESETB

When RESETB of the reset pin equals to Low, it will be in the condition of reset. When it is in the condition of reset, it will make the device recover the initial set. However, in order to avoid the reset noise cause reset, there is a mechanism to judge about whether the reset is needed or not.

The closed interval of Low can be shown as the following.

(Test condition: VDDIO=1.65V~3.6V, VSS=0V, TA=-20°C~+70°C)

Parameter	Symbol	Conditions	Spec			Unit
			Min.	Typ.	Max.	
Reset low pulse width	Trst	-	20	-	-	μs

Table: Reset timing

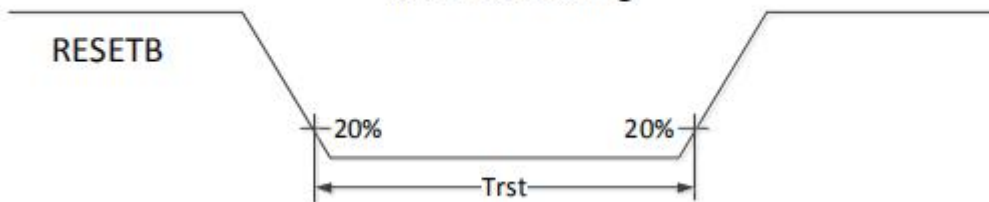

Figure: Reset timing

## 6 Optical Characteristics

Item	Symbol	Condition	Min	Typ	Max	Unit	Remark	Note
Response time	Tr+ Tf	$\theta=0^\circ$ $\phi=0^\circ$ $T_a=25^\circ\text{C}$	-	2	4	ms	FIG 1.	4
Contrast ratio	CR		10000	100000	-	---	FIG 2.	1
Uniformity	WHITE		85	90	-	%	FIG 2.	3
Luminance	Lv		315	350	-	cd/m <sup>2</sup>	FIG 2.	2
Viewing angles	$\theta\text{T}$	$\phi = 90^\circ$	70	85	-	deg	FIG 3.	6
	$\theta\text{B}$	$\phi = 270^\circ$	70	85	-		FIG 3	
	$\theta\text{L}$	$\phi = 180^\circ$	70	85	-		FIG 3	
	$\theta\text{R}$	$\phi = 0^\circ$	70	85	-		FIG 3	
NTSC	-	-	90	105	-	%	-	-
Chromaticity	Red x	$\theta=0^\circ$ $\phi=0^\circ$ $T_a=25^\circ\text{C}$	0.63	0.66	0.69	-	FIG 2.	5
	Red y		0.31	0.34	0.37		FIG 1.	4
	Green x		0.16	0.21	0.26		FIG 2.	1
	Green y		0.68	0.73	0.78		FIG 2.	3
	Blue x		0.09	0.13	0.17		FIG 2.	2
	Blue y		0.02	0.06	0.10		FIG 3.	6
	White x		0.28	0.30	0.32		FIG 3	
	White y		0.29	0.31	0.33		FIG 3	

**Note1.** Contrast Ratio(CR) is defined mathematically by the following formula. For more information see FIG 2.:

$$\text{Contrast Ratio(CR)} = \frac{\text{Average Surface Luminance with all white pixels (P1, P2, \dots)}}{\text{Average Surface Luminance with all black pixels (P1, P2, \dots)}}$$

**Note2.** Surface luminance is the LCD surface luminance with all white pixels. For more information see FIG 2.

$$L_v = \text{Average Surface Luminance with all white pixels(P1, P2, \dots)}$$

**Note3.** The uniformity in surface luminance ( WHITE) is determined by measuring luminance at each test position, and then dividing the maximum luminance of all white pixels by minimum luminance of all white pixels. For more information see FIG 2.

$$\delta \text{ WHITE} = \frac{\text{Minimum Surface Luminance with all white pixels (P1, P2, \dots)}}{\text{Maximum Surface Luminance with all white pixels (P1, P2, \dots)}}$$

**Note4.** Response time is the time required for the display to transition from White to black(Rise Time, Tr) and from black to white(Decay Time, Tf). For additional information see FIG 1.

**Note5.** Chromaticity is the Center point value. For more information see FIG 2.

**Note6.** Viewing angle is the angle at which the contrast ratio is greater than a specific value. For TFT module, the specific value of contrast ratio is 10; For monochrome and color STN module, the specific value of contrast ratio is 2.The angles are determined for the horizontal or x axis and the vertical or y axis with respect to the z axis which is normal to the LCD surface. For more information see FIG 3.

**Note7.** For Viewing angle and response time testing, the testing data is base on Autronic-Melchers's ConoScope. Series Instruments. For contrast ratio, Surface Luminance, Luminance uniformity and CIE, the testing data is base on CS-2000 photo detector.

**Note8.** For TN type TFT transmissive module, Gray scale reverse occurs in the direction of panel viewing angle

**FIG.1. The definition of Response Time**

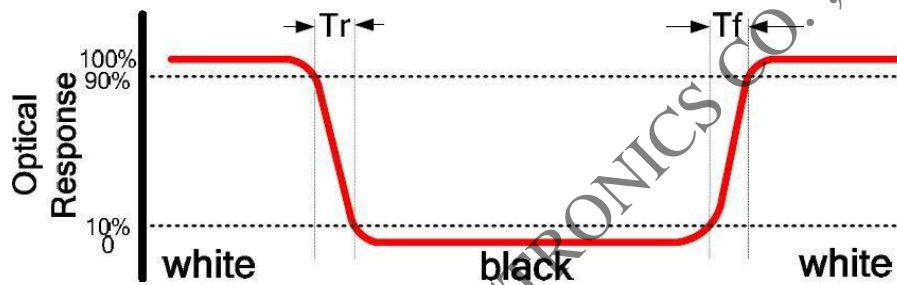

**FIG.2. Measuring method for Contrast ratio, Luminance, Uniformity,Chromaticity**

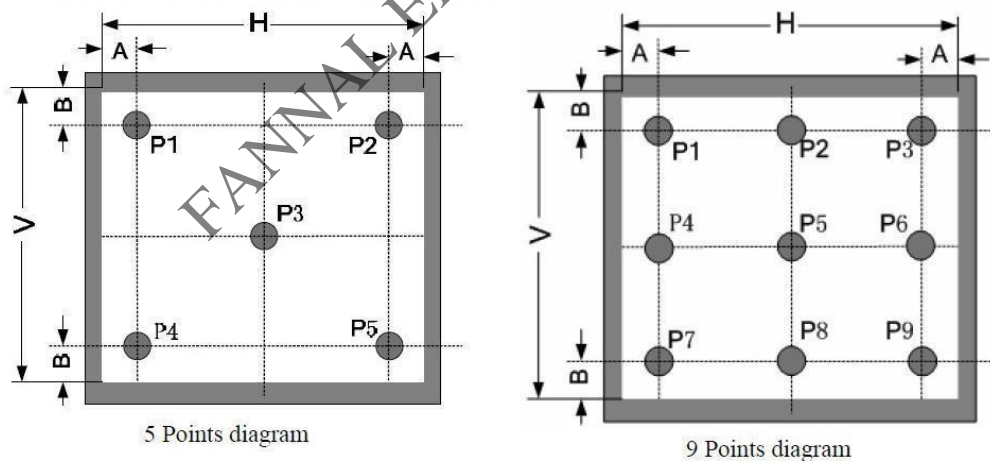

**Fig2 Note1** For TFT Module Test point:9 points( as 9 Points diagram )

Measurement instrument: CS-2000; Light spot size =5mm, 350mm distance from the LCD surface to detector lens.

**Fig2 Note2** For non-TFT Module and Dot-Matrix type Module

- 2.1 If the minimum side size is bigger than 20 mm,the testing method is the same as TFT module.
- 2.2 If the minimum side size is less than 20 mm, then testing 5 point datas (as 5 Pointsdiagram), Both A and B are 5 mm.
- 2.3 Measurement instrument: CS-2000 is priority selected to measure.

Light spot size  $\varnothing=5\text{mm}$ , 350mm distance from the LCD surface to detector lens.

- 24 Measurement instrument : ConoScope will be selected to measure  
 If CS-2000 cannot meet the measurement requirement.  
 Light spot size  $\varnothing=0.2-2.0\text{mm}$ . About 2-3mm distance from the LCD surface to detector lens, but suggest to confirm the best distance on focusing the picture to be clearest when actually measuring.

**Fig2 Note3** For non-TFT Module and non-Dot-Matrix type Module

The test point is defined by the fact size and shape of module, but the center point and four edges should be selected.

- 3.1 Measurement instrument: CS-2000 is priority selected to measure..  
 Light spot size  $\varnothing=5\text{mm}$ , 350mm distance from the LCD surface to detector lens.
- 3.2 Measurement instrument : ConoScope will be selected to measure  
 If CS-2000 cannot meet the measurement requirement.  
 Light spot size  $\varnothing=0.2-2.0\text{mm}$ . About 2-3mm distance from the LCD surface to detector lens, but suggest to confirm the best distance on focusing the picture to be clearest when actually measuring.

**FIG.3. The definition of viewing angles**

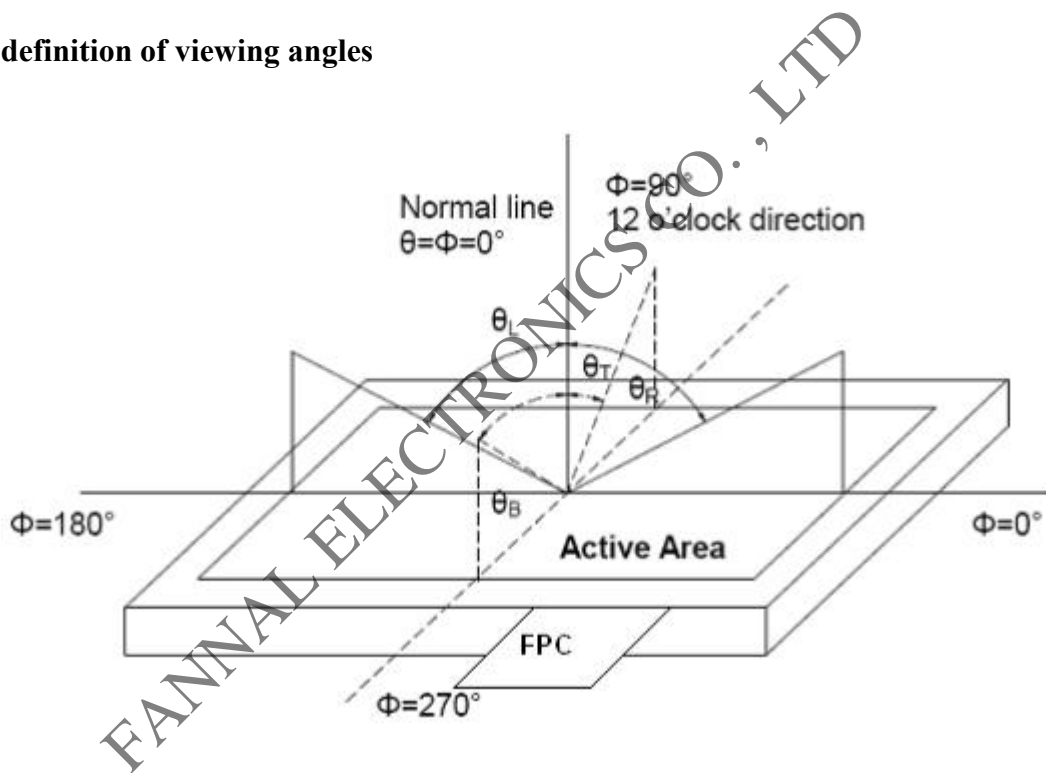

## 7 Environmental / Reliability Tests

No	Test Item	Condition
1	High Temperature Opeartion	Ts= +70°C, 128h
2	Low Temperature Opeartion	Ta= -20°C, 128h
3	High Temperature Storage	Ta= +80°C, 128h
4	Low Temperature Storage	Ta= -40°C, 128h
5	High Temperature & Humidity Storage	Ta= +60°C, 93% RH max, 128h
6	Thermal Shock	-40°C/30 min ~ +85°C/30 min for a total 50 cycles
7	Packing vibration-proof test	2g, f=10->55->10Hz apply in each of X, Y, and Z direction for 30 min
8	Packing Drop test	Drop the packing from 60cm height,6-faces, 3-edges and 1-corner(one time for each)
9	ESD	Air: ±2kV , 150pF/330Ω (Module level, without CG) Contact: ±2kV, 150pF/330Ω (Module level, without CG) 5Points, Each 10times. After one time discharge, touch the ground for 1s.No degradation of OLED performance after this test.

### Note:

1. The test samples have recovery time for 2 hours at room temperature before the function check. In the standard conditions, there is no display function NG issue occurred.
2. All the cosmetic specifications are judged before the reliability stress.

## 8 Inspection criterion

TITLE: FUNCTIONAL TEST & INSPECTION CRITERIA

PAGE 1 OF 5;

This specification is made to be used as the standard of acceptance/rejection criteria for TFT-LCD module product

### 1. Sample plan

Sampling plan according to GB/T2828.1-2003/ISO 2859-1: 1999 and ANSI/ASQC Z1.4-1993, normal level 2 and based on:

Major defect: AQL 0.65

Minor defect: AQL 1.5

### 2. Inspection condition

Viewing distance for cosmetic inspection is about 30cm with bare eyes, and under an environment of 20~40W light intensity, all directions for inspecting the sample should be within 45° against perpendicular line. ((Normal temperature 20~25°C and normal humidity 60±15%RH ); Functional test needs to light up TFT module in the dark room (0~500 lm) for inspection.

### 3. Definition of Inspection Item.

#### 3.1 Definition of inspection zone in LCD.

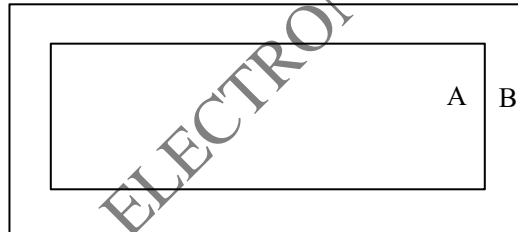

Zone A: viewing area

Zone B: Outside viewing area (invisible area after assembly in customer's product)

Fig.1 Inspection zones in an LCD

Note: As a general rule, visual defects in Zone B are permissible, when it is no trouble for quality and assembly of customer's product.

#### 3.2 Definition of some visual defect

Bright dot	Because of losing all or part function, bad pixel dots appear bright and the size is more than 50% of one dot in which LCD panel is displaying under black pattern.
Dark dot	Dots appear dark and unchanged in size in which LCD panel is displaying under pure red, green, blue picture, or pure whiter picture.



**4 Major Defect**

Item No.	Items to be inspected	Inspection Standard	Classification of defects
4.1	Functional defects	1) No display 2) Display abnormally 3) Missing vertical, horizontal segment 4) Short circuit 5) Excess power consumption 6) Back-light no lighting, flickering and abnormal lighting	major
4.2	Missing	Missing component	
4.3	Outline dimension	Overall outline dimension beyond the drawing is not allowed	

**5 Minor Defect**

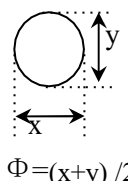
Item No.	Items to be inspected	Inspection Standard					Classification of defects	
5.1	Bright dot /dark dot defect	Zone	Acceptable Qty				B	Minor
			A					
			LCD ≤ 4.3"	4.3" < LCD < 7"	7" ≤ LCD ≤ 10.1"	LCD > 10.1"		
		Bright pixel dot	1	1	1	1	Acceptable	
		Dark pixel dot	2	2	3	3		
		2 bright dots adjacent	0	0	0	0		
		2 dark dots adjacent	0	0	0	0		
Total bright and dark dots	3	3	4	4				
Note: Minimum distance between defective dots is more than 10 mm; Pixel dots' function is normal, but bright dots caused by foreign material and other reasons are judged by the dot defect of 5.2.								
5.2	Dot defect  $\Phi = (x+y) / 2$	Zone	Acceptable Qty				B	Minor
			A					
		Size (mm)	LCD ≤ 4.3"	4.3" < LCD < 7"	7" ≤ LCD ≤ 10.1"	LCD > 10.1"		
		Φ ≤ 0.15	Acceptable	Acceptable	Acceptable	Acceptable	Acceptable	
		0.15 < Φ ≤ 0.20	2	3	3	4		
0.20 < Φ ≤ 0.30								
Note: 1. Minimum distance between defective dots is more than 10 mm; 2. The quantity of defect (adjacent dots) is zero in operating condition.								

**5 Minor Defect**

Item No.	Items to be inspected	Inspection Standard						Classification of defects	
5.3	Linear defect	Zone		Acceptable Qty				Minor	
				A					B
		Length	Width	LCD ≤ 4.3"	4.3" < LCD < 7"	7" ≤ LCD ≤ 10.1"	LCD > 10.1"		
		Ignore	W ≤ 0.03	Acceptable	Acceptable	Acceptable	Acceptable		Acceptable
		L ≤ 5.0	0.03 < W ≤ 0.10	3	3	3	4		
L > 5.0	W > 0.10	0	0	0	0				
Note: 1. Minimum distance between Linear defect is more than 10 mm;									
5.4	Polarizer defect	5.4.1 Polarizer Position (i) Shifting in position should not exceed the glass outline dimension. (ii) Incomplete covering of the viewing area due to shifting is not allowed. (iii) For each side, the polarizer must be larger than 0.8 mm above active area. 5.4.2 Dirt on polarizer Dirt which can be wiped easily should be acceptable. 5.4.3 Polarizer Dent & Air bubble						Minor	
		Zone		Acceptable Qty					
				A					B
		Size (mm)	LCD ≤ 4.3"	4.3" < LCD < 7"	7" ≤ LCD ≤ 10.1"	LCD > 10.1"			
		Φ ≤ 0.20	Acceptable	Acceptable	Acceptable	Acceptable	Acceptable		
0.20 < Φ ≤ 0.30	2	3	3	4					
Note: 1. Minimum distance between defective dots is more than 10 mm;									
5.4.4 Polarizer scratch									
(i) If the polarizer scratch can be seen after cover assembling or in the operating condition, judge by the linear defect of 5.3.									
Zone		Acceptable Qty				Minor			
		A					B		
Length	Width	LCD ≤ 4.3"	4.3" < LCD < 7"	7" ≤ LCD ≤ 10.1"	LCD > 10.1"				
Ignore	W ≤ 0.03	Acceptable	Acceptable	Acceptable	Acceptable		Acceptable		
1.0 < L ≤ 5.0	0.03 < W ≤ 0.20	2	3	3	4				
L > 5.0	W > 0.20	0	0	0	0				
Note: 1. Minimum distance between Polarizer scratch is more than 10 mm;									
(ii) If the polarizer scratch can be seen only in non-operating condition or some special angle, judge by the following:									

**5 Minor Defect**

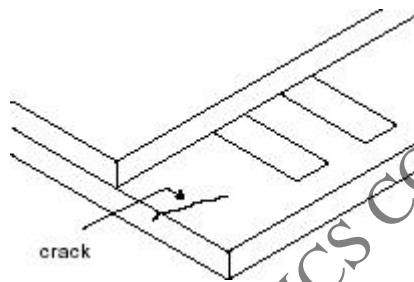
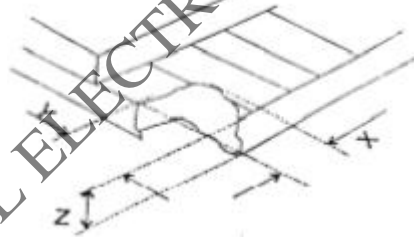
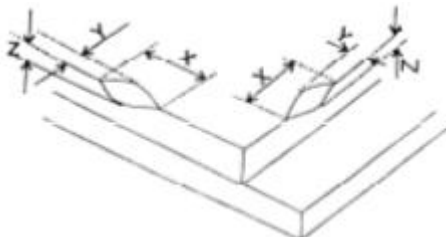
Item No.	Items to be inspected	Inspection Standard	Classification of defects								
5.5	MURA	Using 6% ND filter, it's NG if it can be seen in R,G,B picture.	Minor								
	White/Black dot (MURA)	Visible under: ND6%; $D \leq 0.15\text{mm}$ , Acceptable; $0.15\text{mm} < D \leq 0.5\text{mm}$ , $N \leq 4$ ; $D > 0.5\text{mm}$ , Not allowable.									
5.6	Glass defect	<p>(i) Crack Cracks are not allowed.</p> 	Minor								
		<p>(i) TFT chips on corner</p>  <table border="1" data-bbox="494 1388 1189 1512"> <thead> <tr> <th>X</th> <th>Y</th> <th>Z</th> <th>Acceptable</th> </tr> </thead> <tbody> <tr> <td><math>\leq 3.0</math></td> <td><math>\leq 3.0</math></td> <td>Not more than the thickness of glass</td> <td><math>N \leq 3</math></td> </tr> </tbody> </table> <p>Chips on the corner of terminal shall not be allowed to extend into the ITO pad or expose perimeter seal.</p>	X	Y	Z	Acceptable	$\leq 3.0$	$\leq 3.0$	Not more than the thickness of glass	$N \leq 3$	Minor
		X	Y	Z	Acceptable						
$\leq 3.0$	$\leq 3.0$	Not more than the thickness of glass	$N \leq 3$								
<p>(ii) Usual surface crack</p>  <table border="1" data-bbox="502 1904 1181 2027"> <thead> <tr> <th>X</th> <th>Y</th> <th>Z</th> <th>Acceptable</th> </tr> </thead> <tbody> <tr> <td><math>\leq 1.5</math></td> <td><math>\leq 1.5</math></td> <td>Not more than the thickness of glass</td> <td><math>N \leq 4</math></td> </tr> </tbody> </table> <p>It is only applicable to the upper glass of LCD.</p>	X	Y	Z	Acceptable	$\leq 1.5$	$\leq 1.5$	Not more than the thickness of glass	$N \leq 4$	Minor		
X	Y	Z	Acceptable								
$\leq 1.5$	$\leq 1.5$	Not more than the thickness of glass	$N \leq 4$								

**6. Module Cosmetic Criteria**

Item No.	Items to be inspected	Inspection Standard	Classification of defects
1	Difference in Spec.	Not allowable	Major
2	Pattern peeling	No substrate pattern peeling and floating	Major
3	Soldering defects	No soldering missing No soldering bridge No cold soldering	Major Major Minor
4	Resist flaw on PCB	Visible copper foil ( $\varnothing 0.5$ mm or more) on substrate pattern is not allowed	Minor
5	FPC gold finger	No dirt, breaking, oxidation lead to black	Major
6	Backlight plastic frame	No deformation, crack, breaking, backlight positioning column breaking, obvious nick.	Minor
7	Marking printing effect	No dark marking, incomplete, deformation lead to unable to judge	Minor
8	Accretion of metallic Foreign matter	No accretion of metallic foreign matter (Not exceed $\varnothing 0.2$ mm)	Minor
9	Stain	No stain to spoil cosmetic badly	Minor
10	Plate discoloring	No plate fading, rusting and discoloring	Minor
11	Solder amount	a. Soldering side of PCB Solder to form a 'Filet' all around the lead. Solder should not hide the lead form perfectly. (too much)	Minor
	1. Lead parts	b. Components side ( In case of 'Through Hole PCB' )  Solder to reach the Components side of PCB.	Minor
	2. Flat packages	Either 'Toe' (A) or 'Seal' (B) of the lead to be covered by 'Filet'. Lead form to be assume over Solder.	Minor
	3. Chips	$(3/2) H \geq h \geq (1/2) H$	Minor
11	4.Solder ball/Solder splash	a. The spacing between solder ball and the conductor or solder pad $h \geq 0.13$ mm. The diameter of solder ball $d \leq 0.15$ mm.	Minor
		b. The quantity of solder balls or solder splashes isn't beyond 5 in $600 \text{ mm}^2$ .	Minor
		c. Solder balls/Solder splashes do not violate minimum electrical clearance.	Major
		d. Solder balls/Solder splashes must be entrapped / encapsulated or attached to the metal surface .	Minor
		Note: Entrapped/encapsulated/attached is intended to mean that normal service environment of the product will not cause a solder ball to become dislodged.	

**9 Packing**

----TBD

FANNAL ELECTRONICS CO., LTD

## 10 Precautions For Use of LCD modules

### Handling Precautions

1. The display panel is made of glass and polarizer. As glass is fragile. It tends to become or chipped during handling especially on the edges. Please avoid dropping or jarring. Do not subject it to a mechanical shock by dropping it or impact.
2. The display panel is made of glass and polarizer. As glass is fragile. It tends to become or chipped during handling especially on the edges. Please avoid dropping or jarring. Do not subject it to a mechanical shock by dropping it or impact.
3. If the display panel is damaged and the liquid crystal substance leaks out, be sure not to get any in your mouth. If the substance contacts your skin or clothes, wash it off using soap and water.
4. Do not apply excessive force to the display surface or the adjoining areas since this may cause the color tone to vary. Do not touch the display with bare hands. This will stain the display area and degraded insulation between terminals (some cosmetics are determined to the polarizer).
5. The polarizer covering the display surface of the LCD module is soft and easily scratched. Handle this polarizer carefully. Do not touch, push or rub the exposed polarizers with anything harder than an HB pencil lead (glass, tweezers, etc.). Do not put or attach anything on the display area to avoid leaving marks on it. Condensation on the surface and contact with terminals due to cold will damage, stain or dirty the polarizer. After products are tested at low temperature they must be warmed up in a container before coming in to contact with room temperature air.
6. If the display surface becomes contaminated, breathe on the surface and gently wipe it with a soft dry cloth. If it is heavily contaminated, moisten cloth with one of the following solvents
  - Isopropyl alcohol
  - Ethyl alcoholDo not scrub hard to avoid damaging the display surface.
7. Solvents other than those above-mentioned may damage the polarizer. Especially, do not use the following.
  - Water
  - Ketone
  - Aromatic solventsWipe off saliva or water drops immediately, contact with water over a long period of time may cause deformation or color fading. Avoid contact with oil and fats.
8. Exercise care to minimize corrosion of the electrode. Corrosion of the electrodes is accelerated by water droplets, moisture condensation or a current flow in a high-humidity environment.
9. Install the LCD Module by using the mounting holes. When mounting the LCD module make sure it is free of twisting, warping and distortion. In particular, do not forcibly pull or bend the I/O cable or the backlight cable.
10. Do not attempt to disassemble or process the LCD module.
11. NC terminal should be open. Do not connect anything.
12. If the logic circuit power is off, do not apply the input signals.

13. Electro-Static Discharge Control , Since this module uses a CMOS LSI, the same careful attention should be paid to electrostatic discharge as for an ordinary CMOS IC. To prevent destruction of the elements by static electricity, be careful to maintain an optimum work environment.

Before removing LCM from its packing case or incorporating it into a set, be sure the module and your body have the same electric potential. Be sure to ground the body when handling the LCD modules.

Tools required for assembling, such as soldering irons, must be properly grounded. Make certain the AC power source for the soldering iron does not leak. When using an electric screwdriver to attach LCM, the screwdriver should be of ground potentiality to minimize as much as possible any transmission of electromagnetic waves produced sparks coming from the commutator of the motor.

To reduce the amount of static electricity generated, do not conduct assembling and other work under dry conditions. To reduce the generation of static electricity be careful that the air in the work is not too dry. A relative humidity of 50%-60% is recommended. As far as possible make the electric potential of your work clothes and that of the work bench the ground potential.

The LCD module is coated with a film to protect the display surface. Exercise care when peeling off this protective film since static electricity may be generated.

14. Since LCM has been assembled and adjusted with a high degree of precision, avoid applying excessive shocks to the module or making any alterations or modifications to it.

Do not alter, modify or change the shape of the tab on the metal frame.

Do not make extra holes on the printed circuit board, modify its shape or change the positions of components to be attached.

Do not damage or modify the pattern writing on the printed circuit board.

Absolutely do not modify the zebra rubber strip (conductive rubber) or heat seal connector

Except for soldering the interface, do not make any alterations or modifications with a soldering iron.

Do not drop, bend or twist the LCM.

## Handling precaution for LCM

LCM is easy to be damaged. Please note below and be careful for handling.

### Correct handling:



As above picture, please handle with anti-static gloves around LCM edges.

### Incorrect handling:

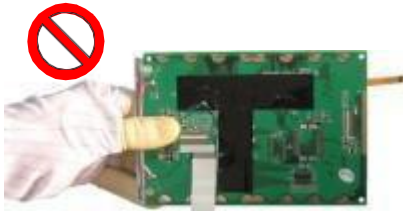

Please don't touch IC directly.



Please don't stack LCM.



Please don't hold the surface of panel.



Please don't hold the surface of IC.

Please don't stretch interface of output, such as FPC cable.

Please don't operate with sharp stick such as pens.



## Storage Precautions

1. When storing the LCD modules, the following precaution are necessary.

Store them in a sealed polyethylene bag. If properly sealed, there is no need for the desiccant.

Store them in a dark place. Do not expose to sunlight or fluorescent light, keep the temperature between 0 °C and 35 °C, and keep the relative humidity between 40%RH and 60%RH.

The polarizer surface should not come in contact with any other objects (We advise you to store them in the anti-static electricity container in which they were shipped).

2. Transportation Precautions

During shipment, please handle with care. The packaging bag can not be broken, step on trap. Packaging Carton layer height can not be over two meters.

The transportation process should pay attention to the waterproof and moisture-proof measures. Product can not be watering. Ethylene sealed bags can not be unsealed.

3. Others

Liquid crystals solidify under low temperature (below the storage temperature range) leading to defective orientation or the generation of air bubbles (black or white). Air bubbles may also be generated if the module is subject to a low temperature.

If the LCD modules have been operating for a long time showing the same display patterns, the display patterns may remain on the screen as ghost images and a slight contrast irregularity may also appear. A normal operating status can be regained by suspending use for some time. It should be noted that this phenomenon does not adversely affect performance reliability.

To minimize the performance degradation of the LCD modules resulting from destruction caused by static electricity etc., exercise care to avoid holding the following sections when handling the modules.

- Exposed area of the printed circuit board.
- Terminal electrode sections.

## Using LCD Mouldle

### 1. Installing LCD Modules

The hole in the printed circuit board is used to fix LCM as shown in the picture below. Attend to the following items when installing the LCM.

Cover the surface with a transparent protective plate to protect the polarizer and LC cell.

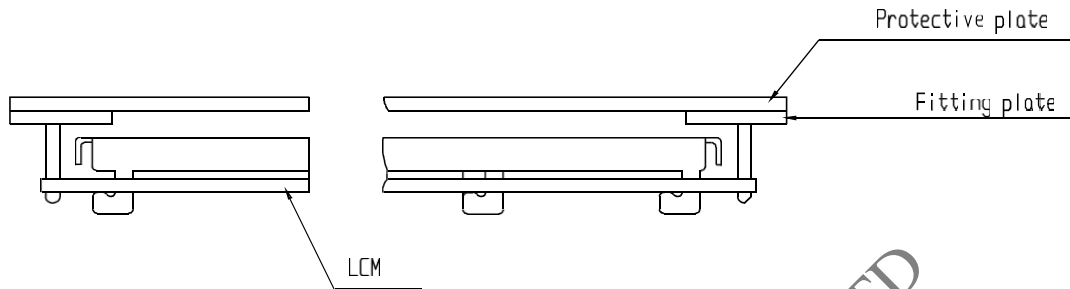

When assembling the LCM into other equipment, the spacer to the bit between the LCM and the fitting plate should have enough height to avoid causing stress to the module surface, refer to the individual specifications for measurements. The measurement tolerance should be 0.1mm.

### 2. Precaution for assemble the module with BTB connector:

Please note the position of the male and female connector position, don't assemble or assemble like the method which the following picture shows

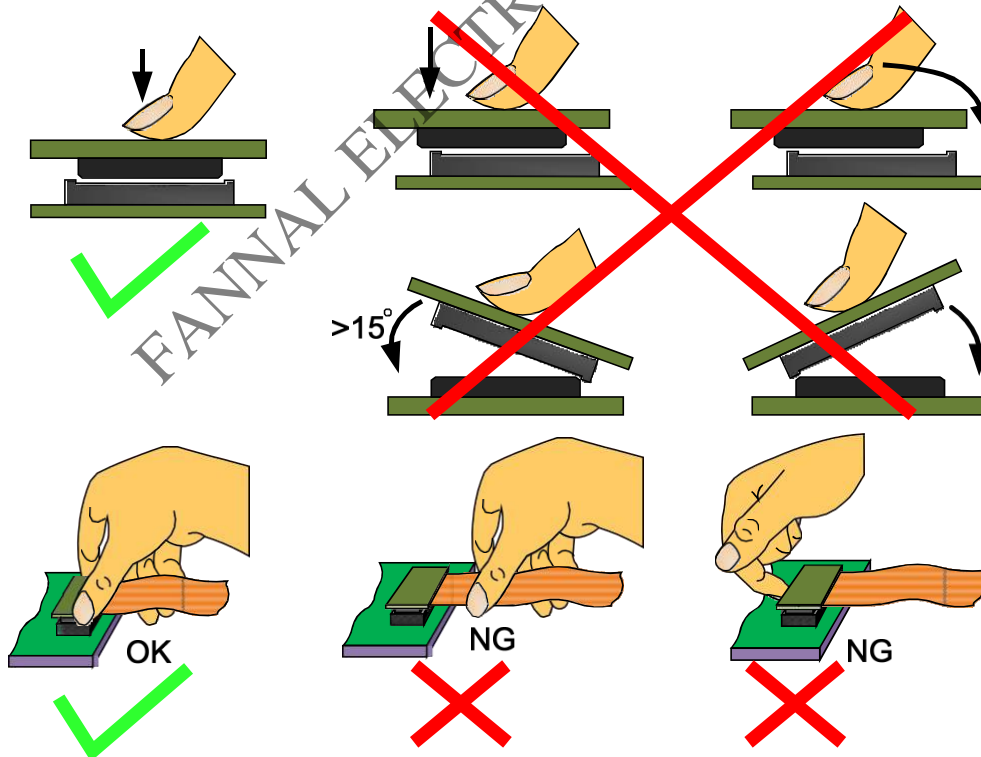

**Precaution for soldering the LCM**

	Manual soldering	Machine drag soldering	Machine press soldering
No RoHS Product	290°C ~350°C. Time : 3-5S.	330°C ~350°C. Speed : 4-8 mm/s.	300°C ~330°C. Time : 3-6S. Press: 0.8~1.2Mpa
RoHS Product	340°C ~370°C. Time : 3-5S.	350°C ~370°C. Time : 4-8 mm/s.	330°C ~360°C. Time : 3-6S. Press: 0.8~1.2Mpa

1. If soldering flux is used, be sure to remove any remaining flux after finishing to soldering operation (This does not apply in the case of a non-halogen type of flux). It is recommended that you protect the LCD surface with a cover during soldering to prevent any damage due to flux spatters.
2. When soldering the electroluminescent panel and PC board, the panel and board should not be detached more than three times. This maximum number is determined by the temperature and time conditions mentioned above, though there may be some variance depending on the temperature of the soldering iron.
3. When remove the electroluminescent panel from the PC board, be sure the solder has completely melted, the soldered pad on the PC board could be damaged.

4. Precautions for Operation

Viewing angle varies with the change of liquid crystal driving voltage (VLCD). Adjust VLCD to show the best contrast.

It is an indispensable condition to drive LCD's within the specified voltage limit since the higher voltage then the limit cause the shorter LCD life. An electrochemical reaction due to direct current causes LCD's undesirable deterioration, so that the use of direct current drive should be avoided.

Response time will be extremely delayed at lower temperature than the operating temperature range and on the other hand at higher temperature LCD's show dark color in them. However those phenomena do not mean malfunction or out of order with LCD's, which will come back in the specified operating temperature.

If the display area is pushed hard during operation, the display will become abnormal. However, it will return to normal if it is turned off and then back on.

A slight dew depositing on terminals is a cause for electro-chemical reaction resulting in terminal open circuit. Usage under the maximum operating temperature, 50%RH or less is required.

Input logic voltage before apply analog high voltage such as LCD driving voltage when power on. Remove analog high voltage before logic voltage when power off the module. Input each signal after the positive/negative voltage becomes stable.

Please keep the temperature within the specified range for use and storage. Polarization degradation, bubble generation or polarizer peel-off may occur with high temperature and high humidity.

## 5. Safety

It is recommended to crush damaged or unnecessary LCDs into pieces and wash them off with solvents such as acetone and ethanol, which should later be burned.

If any liquid leaks out of a damaged glass cell and comes in contact with the hands, wash off thoroughly with soap and water.

FANNAL ELECTRONICS CO., LTD